

MOUNTING OPTIONS

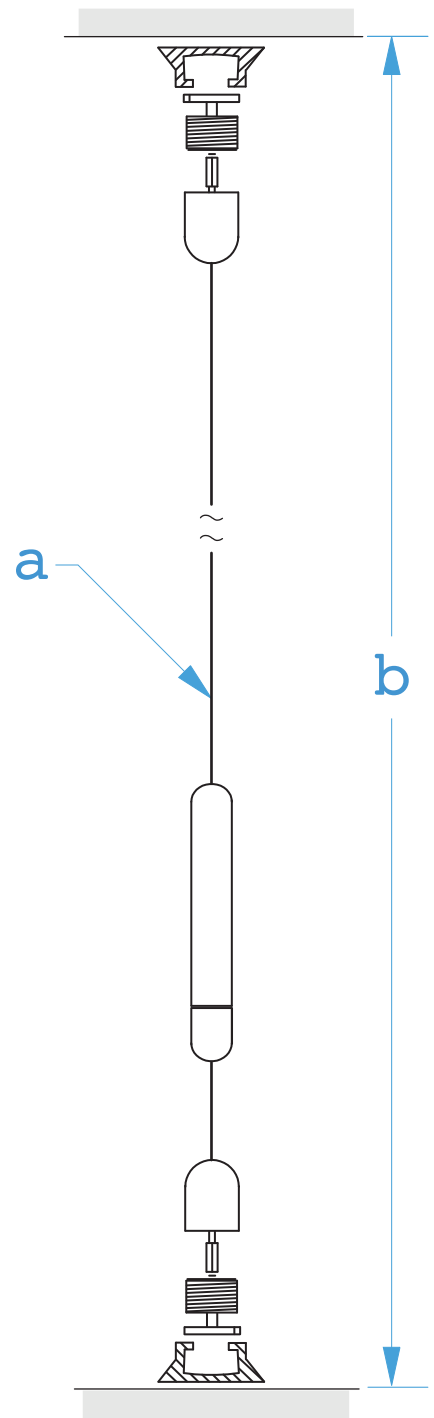

QUICK-FIT CABLE SUSPENSION KIT

Part #	Cable Diameter (a)	Cable Length (b)
CQQ*	1.5mm (1/16")	4M (13' 1-1/2")
	Load Limit	Allen Wrench
	60kg (132lb) *Subject to fixing	1.5mm Metric

*Non-Lit Cable Set – CAN NOT be used with low voltage lighting.