

Longer Studs - Use with 5/8" diameter sign supports to support thicker substrates.

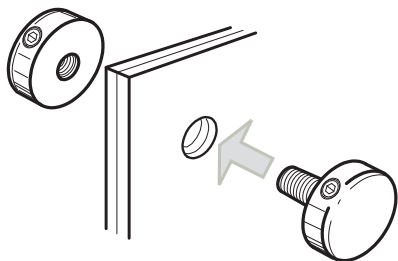

Sandwich Caps - Use two screw caps mounted on a single stud to hold two panels together to create a sandwich-styled display.

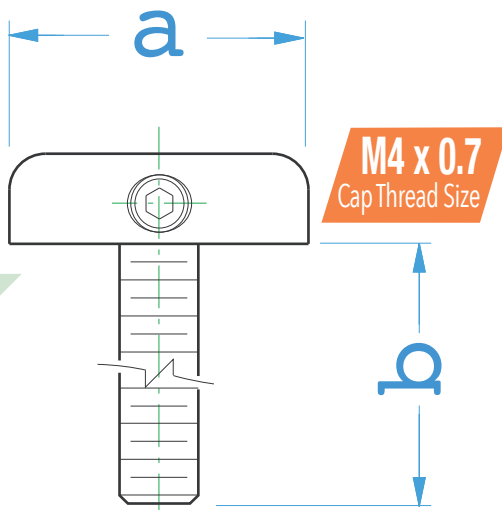

Compatible with
5/8" diameter brass
supports (WM05 and WM05-13)

Ø5/8" SCREW CAP WITH LONGER M4 STUD

Part #	Diameter (a)	Stud Length (b)	Panel Thickness	Panel Hole Dia.
P09/P20 SET	16mm (5/8")	20mm (3/4")	10mm (3/8") max	6mm (15/64")
P09/P25 SET	16mm (5/8")	25mm (1")	16mm (5/8") max	6mm (15/64")
P09/P30 SET	16mm (5/8")	30mm (1-1/4")	20mm (3/4") max	6mm (15/64")
	Stud-Cap Thread Size	Allen Wrench	Load Limit	Finish
	M4 x 0.7	1.5mm Metric	2kg (5lb) each *Subject to fixing	Satin Chrome